

INSTRUMENTS • CONTROLS • VALVES

CLICK TO VISIT OUR WEBSITE

**ARCO**

Engineering, Inc.

SINCE 1954  
www.arcoengineering.com

3317 Gilmore Industrial Blvd.  
Louisville, KY 40213

Ph: (502) 966-3134

Fx: (502) 966-3135

**THE SENSOR  
BOX™**



**THE SENSOR  
BOX™**

## A MODULAR TEMPERATURE SENSOR ASSEMBLY SYSTEM FOR THE INSTRUMENTATION MAINTENANCE PROFESSIONAL



### BENEFITS:

- Improved process uptime
- Reduced expediting & related costs
- Fewer emergency orders
- Lower inventory





### YOU HAVE A PROBLEM...

3:00 PM on a Friday afternoon, and you've just discovered a temperature sensor has failed in an important process. The Safety Engineer wants the process shut down, but you're under pressure to keep production moving. You're going to spend the rest of the afternoon in "Panic Mode," calling every sensor supplier you can think of, begging for the best delivery at a premium. Not very pretty.

If this sounds familiar, then the SENSOR BOX™ was developed to help improve your life. Maintenance or instrument technicians can now build a new temperature sensor assembly, install it and the plant can be back up and running in minutes rather than days! The SENSOR BOX™ is designed for any plant where temperature sensors are an important part of the operation, and downtime is not an option.

### WE CAN HELP

The SENSOR BOX™ is a rugged toolbox containing all of the parts and tools to quickly and easily build the sensor you urgently need. It is:

- **Flexible** - adaptable to most process plants:
  - Power
  - Chemical
  - Refining
  - Offshore Oil Production
- **Comprehensive** - It can include a variety of sensor types and hardware of your choice.
- **Self-contained** - Everything you need to build the right product is at your fingertips.
- **Industrial** - The toolbox and tools are rugged, designed for hard duty.
- **Easy to use** - Complete, easy to follow instructions are included.

### HOW WE DO IT

The Sensor Box™ can be your solution to expediting, high inventory and expensive downtime. One of the challenges in maintaining industrial temperature sensors is the variety. It is difficult for the typical process plant to stock every sensor configuration they might need to replace – until now. By combining common parts into a modular system, a relatively small amount of stock can translate into the variety you need – quickly, and without expediting.

### BUILDING YOUR SENSOR BOX™

A Sensor Box™ is specified in three stages, to maximize its flexibility to your needs:

1. The foundation: the Tool Box and tools required to build sensors (everything you need will be close at hand!)
2. The sensor diameter(s) required – choose based on either 0.250" or 0.188" diameters (need both? Add parts as needed!)
3. The terminal heads required – choose either NEMA 4 or explosion-proof terminal heads (or specify option E99 and customize the box however you like!)

## How to build a part number:

Base	Specify a total of 6 sensor pods using the codes below, along with the quantity (e.g., "P11Q3" indicates (3) J type thermocouples)	Terminal Head Package

Base:  
**SB250** – Sensor Tool Box for 0.250" diameter sensors (contains (6) HS2524 housings, TS1092 nylon wire guides, custom crimper, wire stripper, tube cutter, screwdriver, tape measure and instructions)  
**SB188** – Sensor Tool Box for 0.188" diameter sensors (contains (6) HS1824 housings, TS1094 Teflon strain reliefs, custom crimper, wire stripper, tube cutter, screwdriver, tape measure and instructions.

**E1Q3:**  
 Contains:  
 (3) NEMA 4 rated terminal heads  
 (3) Ceramic terminal blocks  
 (3) Spring-loading kits  
 (3) **US1011** union connectors  
 (6) **NS1002** stainless steel nipples (2" long)

**E2Q3:**  
 Contains:  
 (3) Division 1, explosion-proof terminal heads  
 (3) Ceramic terminal blocks  
 (3) Spring-loading kits  
 (3) **HF1091** union connectors  
 (6) **NS1002** stainless steel nipples (2" long)

**E99:**  
 No standard heads or hardware included.

Specify a quantity of (6) sensor pods from the lists below:

For the SB250 Box		For the SB188 Box		Description
Ordering Number	Quantity	Ordering Number	Quantity	
STYLE MI1113 OR MI1115 GROUNDED THERMOCOUPLES, RATED FOR 900°F (48" fiberglass leads)				
P11Q		P51Q		J calibration
P12Q		P52Q		K calibration
P13Q		P53Q		T calibration
P14Q		P54Q		E calibration
STYLE MI1113TF OR MI1115TF GROUNDED THERMOCOUPLES, RATED FOR 400°F (48" Teflon leads)				
P15Q		P55Q		J calibration
P16Q		P56Q		K calibration
P17Q		P57Q		T calibration
P18Q		P58Q		E calibration
STYLE MI1113 OR MI1115 UNGROUNDED THERMOCOUPLES, RATED FOR 900°F (48" fiberglass leads)				
P26Q		P66Q		J calibration
P27Q		P67Q		K calibration
P28Q		P68Q		T calibration
P29Q		P69Q		E calibration
STYLE MI1113TF OR MI1115TF UNGROUNDED THERMOCOUPLES, RATED FOR 400°F (48" Teflon leads)				
P30Q		P70Q		J calibration
P31Q		P71Q		K calibration
P32Q		P72Q		T calibration
P33Q		P73Q		E calibration
100-ohm platinum, 3-wire RTDs (DIN curve)				
P1Q		P41Q		fiberglass leads, rated for 900°F
P2Q		P42Q		Teflon leads, rated for 400°F
100-ohm platinum, 4-wire RTDs (DIN curve)				
P3Q		N/A		Teflon leads, rated for 400°F



## COMMON PARTS AVAILABLE FOR ALL DIAMETERS

Terminal Heads with 4-Post Terminal Block Included (1/2" NPT process conn.)		
Part Number	Conduit Connection	Description
PH01	1/2"	Aluminum, ordinary locations
PH02	3/4"	Aluminum, ordinary locations (Std. with kit)
PH04	1/2"	Cast iron, ordinary locations
PH05	3/4"	Cast iron, ordinary locations
PH23	3/4"	Black polypropylene, ordinary locations
PH24	3/4"	White polypropylene, ordinary locations
PH47	3/4"	316 stainless steel, ordinary locations
PH50	1/2"	Aluminum, explosion-proof, 3-post block
PH51	3/4"	Aluminum, explosion-proof, 3-post block
Terminal Blocks		
Part Number	Description	
PH41	4-post, ceramic	
PH48	3-post, ceramic, for PH50 and PH51 heads	
Carbon Steel Nipples (1/2" NPT)		
NC1001	1" long	
NC1002	2" long	
NC1003	3" long	
NC1004	4" long	
NC1006	6" long	

Stainless Steel Nipples (1/2" NPT)	
NS1001	1" long
NS1002	2" long
NS1003	3" long
NS1004	4" long
NS1006	6" long
Plugs and Jacks (see next page for crimp insert)	
PT05-	Thermocouple plug (specify J, K, E or T); e.g., PT05-J
PT05-3	3-pin RTD plug
PT06-	Thermocouple jack (specify J, K, E or T); e.g., PT06-K
PT06-3	3-pin RTD jack
PA10	Wire clamp
Unions (1/2" NPT)	
US1011	Stainless steel, ordinary location
HF1091	Plated steel, explosion-proof

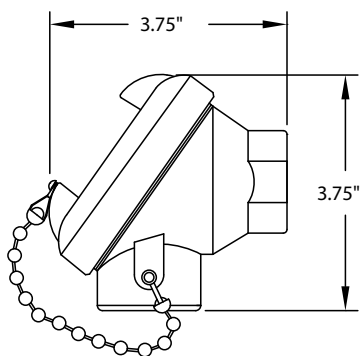

PH02

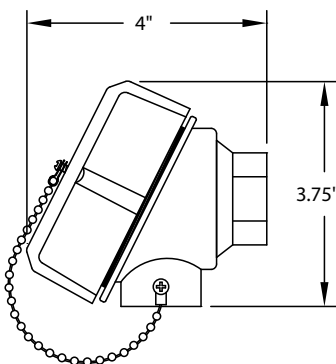

PH50

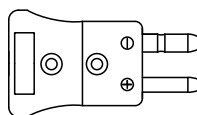

PT05

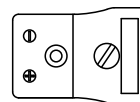

PT06

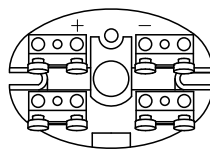

PH41

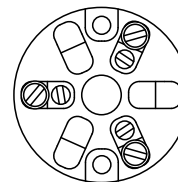

PH48

## PARTS DESIGNED FOR USE WITH .250" O.D. SENSORS

Thermocouple Sensor Pods* (standard limits of error with 48" leads)	
MI1113_U	Ungrounded junction, fiberglass insulation (specify J, K, E or T calibration; e.g., MI1113KU)
MI1113_G	Grounded junction, fiberglass insulation (specify J, K, E or T calibration; e.g., MI1113KG)
MI1113TF_U	Ungrounded junction, Teflon® insulation (specify J, K, E or T calibration; e.g., MI1113TFJU)
MI1113TF_G	Grounded junction, Teflon® insulation (specify J, K, E or T calibration; e.g., MI1113TFJG)
*For dual element, specify as JJ, KK, EE or TT	
RTD Sensor Pods (100-ohm, Class B, 0.00385 alpha with 48" leads)	
Part Number	Description
RT1254	3-wire, fiberglass insulation (std)
RT1260	3-wire, Teflon® insulation (std)
RT1257	4-wire, Teflon® insulation
RT1276	4-wire, fiberglass insulation
Housings (stainless steel, one closed end)	
HS2512	0.250" O.D. x 12" long
HS2524	0.250" O.D. x 24" long (std. with kit)
HS2536	0.250" O.D. x 36" long
HS2548	0.250" O.D. x 48" long
Spring-Loading Kits	
AC1087	For 0.250" housings
Spring-Loaded Hex Fittings (1/2" NPT)	
PF14	Stainless steel, for 0.250" housings
PF22	Stainless steel, with o-ring seal for 0.250" housings
Compression Fittings	
PF65	1/4" NPT, 316 stainless steel body and ferrule
PF66	1/4" NPT, 316 stainless steel body; Teflon® ferrule
PF73	1/2" NPT, 316 stainless steel body and ferrule
PF74	1/2" NPT, 316 stainless steel body; Teflon® ferrule
Crimp Insert for Plug	
B1250	Brass crimp insert, for 0.250" housings
Strain Reliefs (Bag of 10)	
TS1092	Nylon grommet for 0.250" housings
Armor Cable Kit	
TS1093	3' stainless armor and adaptor for 0.250" housings

## PARTS DESIGNED FOR USE WITH .188" O.D. SENSORS

Thermocouple Sensor Pods* (standard limits of error with 48" leads)	
MI1115_U	Ungrounded junction, fiberglass insulation (specify J, K, E or T calibration; e.g., MI1115KU)
MI1115_G	Grounded junction, fiberglass insulation (specify J, K, E or T calibration; e.g., MI1115KG)
MI1115TF_U	Ungrounded junction, Teflon® insulation (specify J, K, E or T calibration; e.g., MI1115TFJU)
MI1115TF_G	Grounded junction, Teflon® insulation, 48" long (specify J, K, E or T calibration; e.g., MI1115TFJG)
*For dual element, specify as JJ, KK, EE or TT	
RTD Sensor Pods (100-ohm, Class B, 0.00385 alpha with 48" leads)	
Part Number	Description
RT1184	3-wire, fiberglass insulation
RT1256	3-wire, Teflon® insulation
Housings (stainless steel, one closed end)	
HS1812	0.188" O.D. x 12" long
HS1824	0.188" O.D. x 24" long
HS1836	0.188" O.D. x 36" long
HS1848	0.188" O.D. x 48" long
Spring-Loading Kits	
AC1088	For 0.188" housings
Spring-Loaded Hex Fittings (1/2" NPT)	
PF13	Stainless steel, for 0.188" housings
PF21	Stainless steel, with o-ring seal for 0.188" housings
Compression Fittings	
PF55	1/4" NPT, 316 stainless steel body and ferrule
PF56	1/4" NPT, 316 stainless steel body; Teflon® ferrule
PF59	1/2" NPT, 316 stainless steel body and ferrule
PF60	1/2" NPT, 316 stainless steel body; Teflon® ferrule
Crimp Insert for Plug	
B1188	Brass crimp insert, for 0.188" housings
Strain Reliefs (Bag of 10)	
TS1094	Teflon® strain relief for 0.188" housings

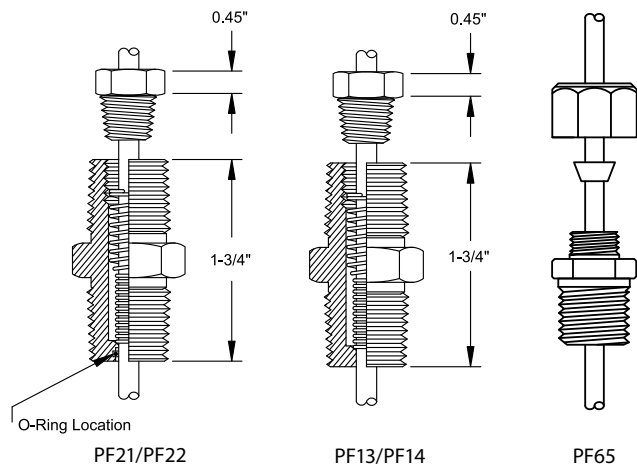



## OUTLINE DRAWINGS OF SOME OF THE ASSEMBLIES THAT CAN BE BUILT USING SENSOR BOX™ COMPONENTS

Dimensional drawings for all models may be found at [www.appliedsensortech.com](http://www.appliedsensortech.com)

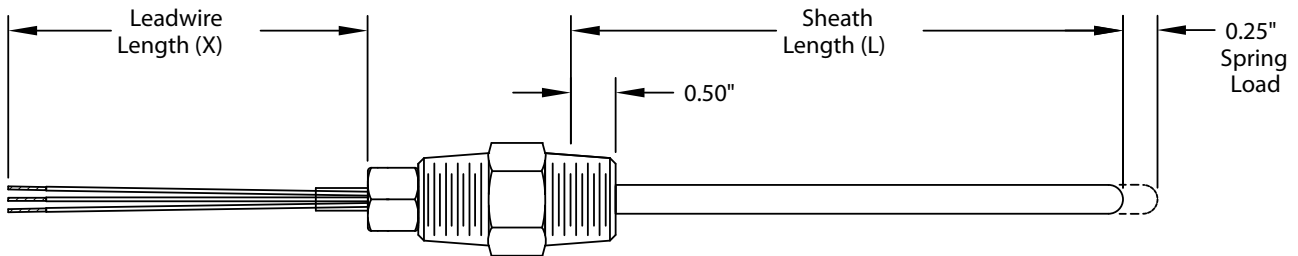
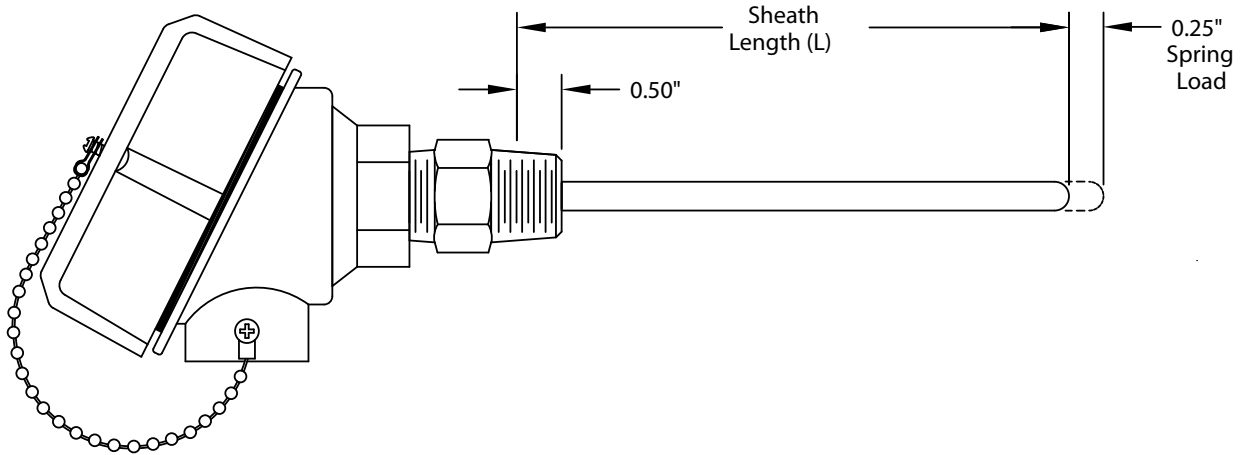
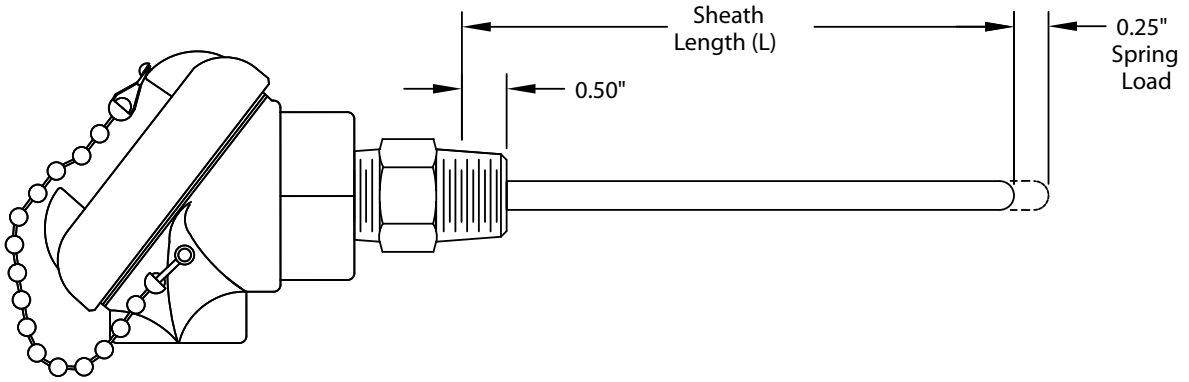

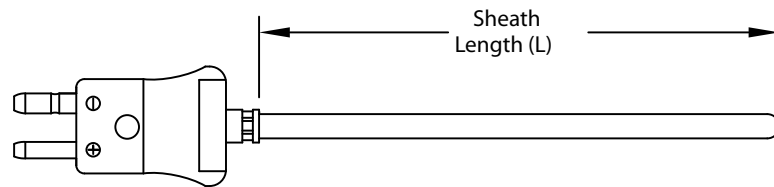
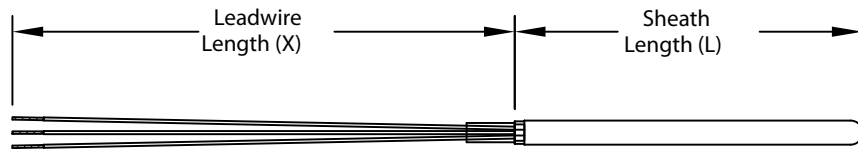
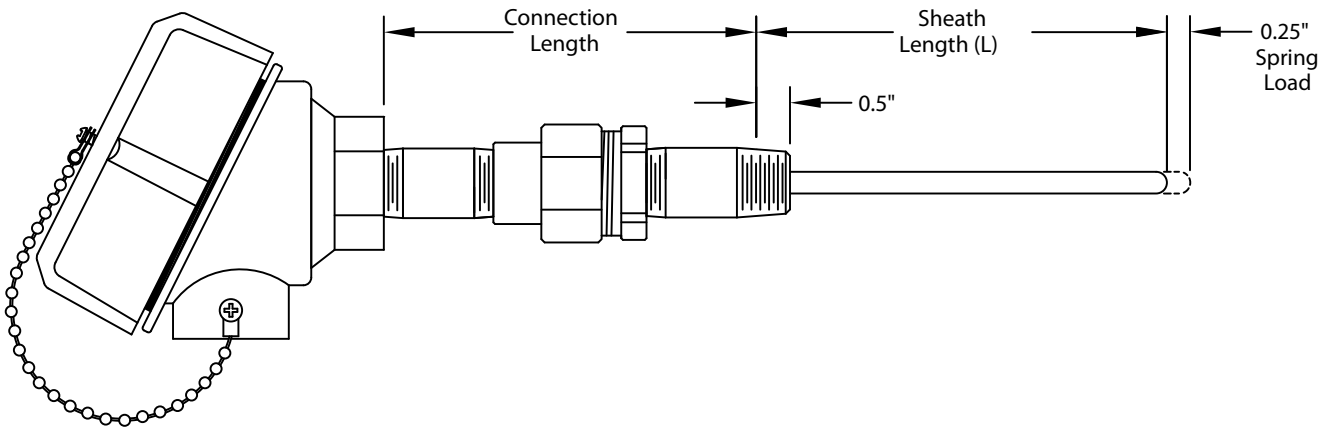
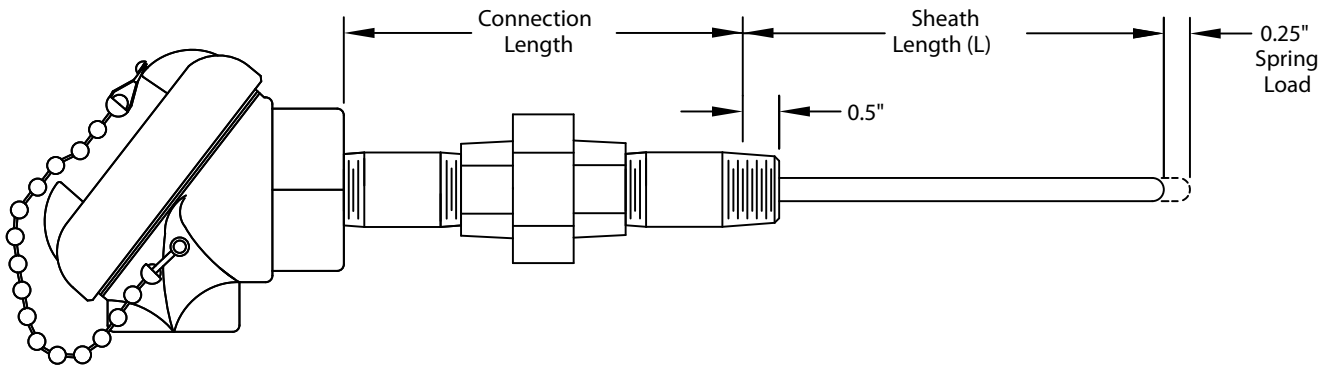

**A**ppplied Sensor Technologies, a division of United Electric Controls, is a major manufacturer of thermocouple, RTD, thermistor and other temperature sensor assemblies. ISO 9001:2000 certified and a leading practitioner of JIT and Lean Manufacturing methods, Applied Sensor Technologies has expertise in a wide variety of process applications, from the blast furnace to the blast freezer; from chemical processing to food processing. Please visit our website: [www.appliedsensortech.com](http://www.appliedsensortech.com), or give us a call at 617-923-6966!



United Electric Controls  
31 Old Stage Road  
Hampton Falls, NH 03844  
Phone: 617-899-1132  
email: [northeastsales@ueonline.com](mailto:northeastsales@ueonline.com)

United Electric Controls  
1022  
Conye  
Phone  
email: [southeastsales@ueonline.com](mailto:southeastsales@ueonline.com)

United Electric Controls  
3317 Gilmore Industrial Blvd.  
Louisville, KY 40213  
Ph: (502) 966-3134  
Fx: (502) 966-3135  
email: [westcoastsales@ueonline.com](mailto:westcoastsales@ueonline.com)

#### U.S. SALES OFFICES

United Electric Controls  
33018 Weatherby Court  
Fulshear, Texas 77441  
Phone: 832-457-6138  
email: [southwestsales@ueonline.com](mailto:southwestsales@ueonline.com)

United Electric Controls  
28 N. Wise Ave.  
Freeport, IL 61032  
Phone: 815-341-2588  
email: [midwestsales@ueonline.com](mailto:midwestsales@ueonline.com)

United Electric Controls  
5829 Grazing Court  
Mason, OH 45040  
Phone: 513-535-5486  
email: [midatlanticsales@ueonline.com](mailto:midatlanticsales@ueonline.com)

United Electric Controls  
27 Summit Terrace  
Sparta, NJ 07871  
Phone: 973-271-2550  
email: [easternsales@ueonline.com](mailto:easternsales@ueonline.com)

#### INTERNATIONAL OFFICES

**CHINA**  
United Electric Controls  
Room 1011, 10th Flr,  
Huai Hai Zhonghua Building  
No. 885, Renmin Road, Luwan District  
Shanghai 200010, P.R. China  
Phone: +8621-6255 8059  
email: [chinasales@ueonline.com](mailto:chinasales@ueonline.com)

**BEIJING**  
Room 3A01, No. 9, Yingu Bldg.  
North-West Si Huan Road,  
Haidian Dis.,  
Beijing, 100080  
China  
Phone: +86 (-10) -62800956  
email: [beijingsales@ueonline.com](mailto:beijingsales@ueonline.com)

**MEXICO**  
United Electric Controls  
Zacatecas # 206, Suite 20  
Col Guadalupe CP 89120  
Tampico, Tamaulipas  
Mexico  
Phone: 833-132-3726  
email: [latinamericasales@ueonline.com](mailto:latinamericasales@ueonline.com)

**ASIA-PACIFIC**  
United Electric Controls, Far East  
No. 1-2-2, 2nd Floor  
Jalan 4/101C  
Batu 5, Jalan Cheras  
56100 Kuala Lumpur, Malaysia  
Phone: 603-9133-4122  
email: [fareastsales@ueonline.com](mailto:fareastsales@ueonline.com)

**EASTERN EUROPE & SCANDINAVIA**  
United Electric Controls  
05-806 Komorow  
Kujawska 5, Poland  
Phone: +48 22 499 4804  
email: [easterneuropesales@ueonline.com](mailto:easterneuropesales@ueonline.com)

**GERMANY**  
United Electric Controls  
An Der Zentlinde 21  
D-64711 Erbach, Germany  
Phone: 496-062-7400  
email: [europesales@ueonline.com](mailto:europesales@ueonline.com)

**RUSSIA**  
United Electric Controls, Moscow  
Elninskaya str., 15-140  
Moscow, Russia 121552  
Phone: +7 (095) 792-88-06  
email: [russiansales@ueonline.com](mailto:russiansales@ueonline.com)

**INDIA**  
United Electric Controls  
#402, Aries Avenue - 1  
United Colony, Sama, Baroda  
Gujart, India 390 008  
Phone: +91-265-2788654  
email: [indiasales@ueonline.com](mailto:indiasales@ueonline.com)

#### DIVISIONS

Precision Sensors  
50 Seemans Lane  
Milford, CT 06460  
Phone: 203-877-2795  
Fax: 203-877-8752  
[www.precisionensors.com](http://www.precisionensors.com)

United Electric Controls  
180 Dexter Avenue, P.O. Box 9143  
Watertown, MA 02471-9143  
Telephone: 617-926-4354  
Fax: 617-926-1000  
[www.ueonline.com](http://www.ueonline.com)

#### CANADA OFFICES

**EASTERN**  
68 Mosley Crescent  
Brampton, Ontario  
Canada L6Y 5C8  
Phone: 905-455-5131  
FAX: 905-455-5131

**UE** **APPLIED SENSOR TECHNOLOGIES**  
A Division of UNITED ELECTRIC CONTROLS  
180 Dexter Avenue, P.O. Box 9143  
Watertown, MA 02471-9143 USA  
Telephone: 617-923-6966 Fax: 617-926-8411  
[www.appliedsensortech.com](http://www.appliedsensortech.com)